

240 • 280 SERIES

Pump Manual

HORIZONTAL FLEXIBLE COUPLED

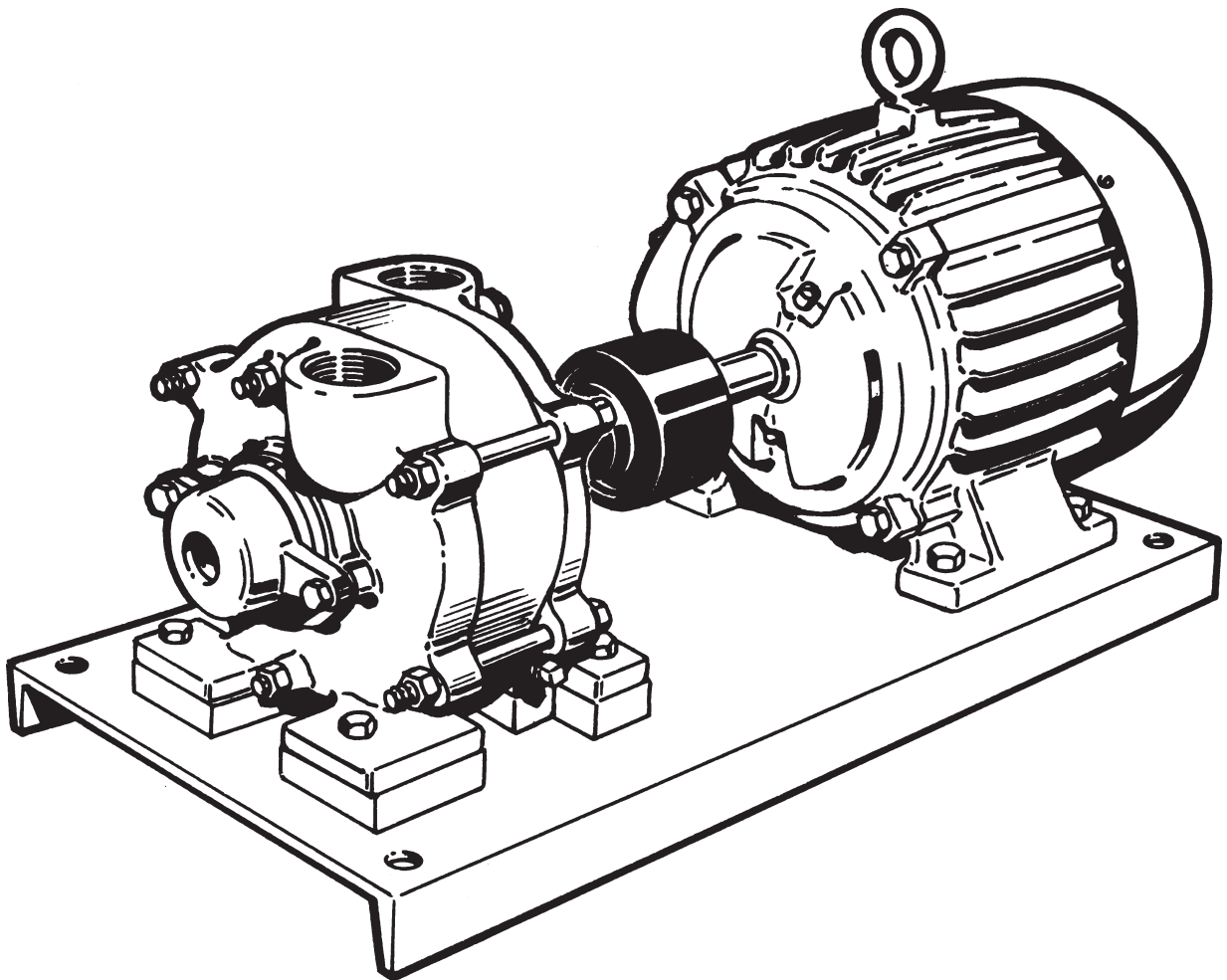

MTH PUMPS

401 West Main Street • Plano, IL 60545-1436
Phone: 630-552-4115 • Fax: 630-552-3688
Email: SALES@MTHPUMPS.COM
<http://WWW.MTHPUMPS.COM>

1. General Instructions

HORIZONTAL FLEXIBLE COUPLED PUMPS

- A. Inspection of Equipment
- B. Storage
- C. Placing Stored Pumps Into Service
- D. Application Considerations
- E. Recommended Spare Parts

When properly installed and given reasonable care and maintenance, regenerative turbine pumps should operate satisfactorily for many years. Because of the high differential pressures expected in a regenerative turbine pump, close running clearances are used to reduce internal losses. Abrasive particles, even microscopic ones, in high enough concentrations, can open up the close clearances between internal components. For critical services it is recommended that you keep an identical pump for stand-by use.

1A Inspection of Equipment

Immediately upon receipt of the shipment, inspect the equipment for damage or missing components. Check the shipping manifest and report any damage or shortage to the Transportation Company's local agent. Inspect the crate and any wrapping material before discarding. Parts or accessories are sometimes wrapped individually or fastened to the skid.

Put the instructions that came with the shipment in a safe place where they will be available to those who will be using them for installation and service..

1B Storage

If the pump is to be stored before use, it should be inspected as described in 1A, recrated and stored in a dry location. Standard shipping containers are not suitable for outdoor storage. In some areas, it may be necessary to cover the pump's exterior surface with oil or other rust inhibiting coating. All units are tested at the factory with a water/corrosion inhibitor solution, some of which will remain inside the pump upon receipt. If units are flushed out prior to storage, this inhibitor will be removed and proper care must be taken to prevent product deterioration from improper storage.

For storage beyond 30 days, a corrosion inhibiting protective fluid

should be added to the internal pump cavities. Fluids used in the pump should be selected for compatibility with pump materials. This is very important when optional seal and gasket materials have been used. Protective caps on the inlet and outlets should also be used. Caps alone are not sufficient protection.

1C Placing Stored Pumps Into Service

Special care must be taken when placing stored pumps into service. First clean the outside and flush out the inside with a process compatible fluid. Try to turn the pump using the coupling. Applying torque to the motor fan blades is not recommended. If the impeller does not break loose immediately, fill the pump with a process compatible fluid and try again in a few hours.

If this fails, read the disassembly-reassembly instructions. With an understanding of which are the bolts used to clamp the entire assembly together, loosen each of them exactly three full turns. After filling the pump with water again, up to 50 foot pounds of torque may be applied to the coupling without fear of ruining the impeller vanes. It should begin to turn well before this force is reached. Continue turning the pump while the various fasteners are returned to their original positions.

If the unit still won't turn over, DO NOT apply further force. Refer to the Disassembly/Reassembly Instructions in Section 5 to determine the cause of the problem.

1D Application Considerations

1D1 Electrical Wiring

All electrical equipment and wiring should conform to local and National Electrical Codes. Use the motor manufacturer's instructions for connecting the motor. Note the correct rotation and wiring diagrams on the assembly. Make sure the motor rotation and speed matches that required for the pump.

1D2 Construction Materials

While it is reasonable to assume that good judgement has been used in selecting all the materials in the pump for compatibility with process fluids, actual conditions sometimes vary from original specifications. Also, typical

material selection charts do not consider all the temperature, pressure, and fluid variables. The customer's engineer should be consulted for final judgement on the best materials for critical process applications.

1D3 Valves

The first valve to be considered for a regenerative turbine pumping system might be a pressure relief valve. Because this type of pump has a horsepower requirement similar to that of a positive displacement pump (constantly rising hp along with pressure increases) a relief valve can be effectively used to limit horsepower. This is helpful when a non-overloading motor is specified. It can be of critical importance if the system flow rate can vary widely.

There are almost no circumstances where a flow modulating valve will work successfully in a regenerative turbine pumping system. The steep pumping characteristic, typical of these pumps, produces very large pressure changes with small variations in flow rate. As a result, the modulating flow from the valve introduces sharp pressure shock waves that shorten pump life and may cause damage to other pieces of equipment in the system.

A swing check valve is recommended in the suction line even when the pump inlet is only slightly higher than the fluid source. It should be the same size as the pump inlet or sized based on reasonable fluid friction losses.

A foot valve is recommended when lifting fluid from a sump. This will save wear and tear on any pump, even those equipped with self priming capability.

A Y-Strainer is recommended immediately ahead of the pump on any newly constructed system. This is advisable due to the probability that foreign material large enough to damage pump clearances may remain even though the piping has been flushed.

Valves in the outlet piping of a regenerative turbine pump should always be open as far as possible when the pump is started. This will reduce the start-up load on the pump and motor. Never start the pump with the discharge valve closed.

Inlet valving should be open when starting any pumping system. Without some fluid in the pump, it can gall and lock up the impellers. Violent pump failure will result from continued operation with the inlet valve closed.

1D4 Priming

Regardless of whether self-priming equipment is used or not, always fill the pump and vent it of air before starting, for best seal and pump life. Under most circumstances, regenerative turbine pumps can be made to self-prime as long as a small amount of fluid can be recirculated through the impeller and the fluid doesn't heat up noticeably.

1D5 NPSH (Net Positive Suction Head)

The NPSH required varies with every size and capacity of pump. The NPSH required by your unit can be obtained from the performance curves or from your MTH representative.

If the NPSH available is not equal to or greater than that required by the pump, it must be increased or a different pump selected. The usual method for increasing NPSH is to raise the static head on the pump inlet, (H_s).

By definition, NPSH means: "Net Positive Suction Head" above the vapor pressure of the pumped liquid available at the centerline of the pump. It should always be given in feet of pumped liquid. The NPSH is actually a measurement of the amount of energy available in the pumped liquid to produce the required absolute entrance velocity in the pump. If a pump requires more energy (or NPSH) than is available at a given capacity, the pressure at the inlet will fall below the

vapor pressure of the pumped liquid and loss of performance will result as the liquid vaporizes.

P_s = Pressure in the suction vessel in PSIA.

P_{vp} = Vapor pressure of the pumped fluid in PSIA.

H_s = Static height of the pumped fluid above (+) or below (-) the centerline of the pump in feet.

H_f = All friction losses from the vessel to the pump in feet. Then, $NPSH = 2.31 \left(\frac{P_s - P_{vp}}{sp. gr.} \right) + H_s - H_f$

For boiling liquids, P_s and P_{vp} are equal. This item then becomes zero and can be omitted from the equation.

1D6 Noise

Regenerative turbine pumps typically produce a high pitched whine that increases in intensity as the differential pressure produced in the pump increases. While high frequency sound is attenuated more easily than lower frequencies, piping structures and the fluids in them readily transmit noise. Motors, bearings, and other rotating components add to the noise and sometimes create objectionable harmonics.

Adequate support for the inlet and discharge piping is important for noise reduction.

1D7 Freezing

When ambient temperatures drop below the freezing point of the fluid in a pump, consideration should be given to heating, insulating, or draining the pump. If you choose to drain the pump, and it will only be for a short period, first remove the drain plugs, then drain the

inlet and outlet lines. Carefully blow out the pump with compressed air to clear all internal cavities of fluid.

1E Recommended Spare Parts

FOR CRITICAL SERVICES - a duplex installation, with two identical pumping units in parallel, is the safest, and many times, the most cost effective choice.

FOR IMPORTANT SERVICES - a standby pump, ready for installation, is advised.

Special pricing and new pump warranty is offered for factory rebuilding. Turn around time can be as short as one or two days for standard models.

FOR ROUTINE MAINTENANCE

- only the mechanical seals and a complete set of "O" ring gaskets are recommended. Should additional components show wear, they are available from stock at the factory.

FOR SERVICING A PUMP THAT DOES NOT PRODUCE RATED HEAD

- mechanical seals, "O" ring gaskets, impeller, and channel rings.

FOR REBUILDING A PUMP

- all the components required for servicing, plus bearings, shaft, and drive keys for flexible coupled pumps, should be obtained. A factory rebuild should be considered whenever your disassembly indicates rebuilding is necessary, as this is usually more economical.

The factory recommendation for spare parts are all of those listed for rebuilding a pump and are shown on the exploded view drawings for each individual type of pump.

240 • 280 SERIES

2. Installation

FLEXIBLE COUPLED PUMPS

- A. Location
- B. Foundation
- C. Leveling
- D. Alignment
- E. Piping
- F. Typical Installation

In order to insure that pumping equipment is installed properly and to obtain reliable pump operation, it is recommended that only experienced, qualified erecting

engineers undertake this task. Read the instructions thoroughly before beginning.

2A Location

The first consideration for locating a pump is elevation. The lowest possible elevation using the shortest possible suction piping is usually the best. Locations should be compared by making inlet head calculations, including all friction losses. The one producing the highest inlet pressure should be selected. One reason for

this precaution is that, the greater the inlet pressure, the less likelihood of NPSH problems. Also, a flooded suction is particularly helpful on start-up when the seals or the entire pump can be ruined, because it is not properly primed and purged of air.

A dry, easily accessible location is also important. Allow ample clearance around the unit for free air circulation. If a dry location is not available, the pump can be mounted on a foundation, above the floor. Specify motor enclosure,

pump materials, or coatings to suit the worst conditions expected. Place the pump so that it can be easily inspected and serviced during operation. Sufficient head room should be provided, particularly when lifting devices will be used for heavier assemblies.

2B Foundation

Baseplates alone are not rigid enough to maintain alignment of the unit. The pump foundation is used as a support for the baseplate to maintain alignment of the unit. If the baseplate is to be grouted to the foundation, it is only necessary to embed the edges. It is unnecessary to completely fill under the baseplate. DO NOT grout the unit to the foundation until it has been properly aligned.

The foundation must be a permanent rigid installation of concrete or other material of sufficient mass to absorb all normal vibrations. Locate the foundation bolts using a layout or template in relation to the suction and discharge piping. If concrete is being used, foundation bolts of the specified size can be enclosed in a pipe sleeve two to three diameters larger than the bolts to compensate for minor variations in alignment.

2C Leveling

If the unit is received with the pump and motor mounted on the baseplate:

1. Place the unit in position.
2. Disconnect the coupling halves. Do not reconnect until all alignment procedures have been completed.
3. Support the baseplate on metal shims or wedges having a small taper. (Refer to Figure 2-1)
 - a. Place shims close to the foundation bolts. (Refer to Figure 2-2)

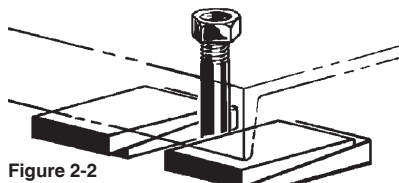

Figure 2-2

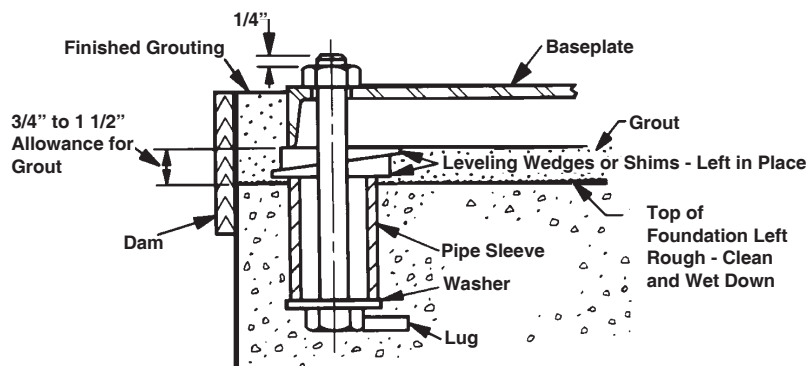

Figure 2-1 Foundation

- b. Also place shims close to where the greatest weight is located.
 4. Check the baseplate for distortion:
 - a. Place a straightedge along the baseplate to determine if it is distorted.
 - b. Adjust the shims until the baseplate is not distorted.
 5. Use a section of pipe to determine if the inlet and discharge openings are vertical and located properly.
 6. Correct the positions, if necessary, by adjusting the shims.
1. Place a straightedge across the two coupling flanges.
 2. Measure the maximum offset (A), Figure 2-3, at various points around the periphery of the coupling. DO NOT rotate the coupling.
 3. If the maximum offset exceeds the Parallel dimension in Chart 1 for your sleeve size, loosen the motor or pump and place thin metal shims under the motor or pump feet until the offset is corrected.

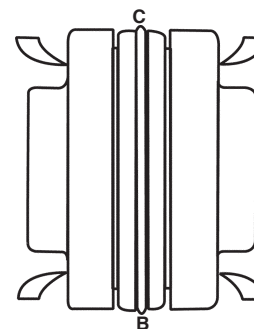

Figure 2-4

2D Alignment

Although flexible coupled pumps are carefully aligned prior to crating and shipping, it is very likely that strains imposed during transit have altered the alignment. Complete the following steps after the unit has been placed on the foundation and leveled.

To check the PARALLEL alignment: (Refer to Figure 2-3)

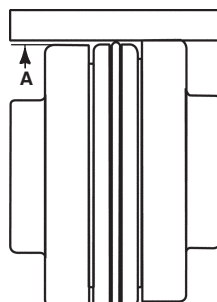

Figure 2-3

4. Torque down the motor or pump.
5. Recheck alignment.

To check the ANGULAR alignment: (Refer to Figure 2-4)

1. Using a micrometer or caliper, measure from the outside of one flange to the outside of the other at intervals around the periphery of the coupling. DO NOT rotate the coupling.
2. Determine the maximum (B) and minimum (C) dimensions.
3. If the difference between the maximum and minimum exceeds

the Angular dimension in Chart 1 for your sleeve size, loosen the motor or pump and place thin metal shims under the motor or pump feet until the misalignment is corrected.

CHART 1

COUPLING TYPES JE, J, S			
MAX. RPM & ALLOWABLE MISALIGNMENT			
SLEEVE SIZE	MAXIMUM RPM	PARALLEL A	ANGULAR B-C
3	9200	.010	.035
4	7600	.010	.043
5	7600	.015	.056
6	6000	.015	.070
7	5250	.020	.081
8	4500	.020	.094

4. Torque down the motor or pump.
5. Recheck the parallel alignment above.

If the parallel or angular misalignment is great, this is an indication of baseplate distortion and must be corrected first, refer to 2C Leveling.

After all leveling and alignment operations have been completed, piping can begin. After the piping has been completed, refer to 2E1 Piping Alignment. Alignment of the unit must be rechecked to make certain that no piping strains are causing distortion. After approximately two weeks of operation, check the alignment again to make sure that temperature changes, piping strain, or foundation variations have not caused misalignment. If alignment has been maintained over this period, the pump and motor can be doweled to the baseplate.

2E Piping

2E1 Alignment

It is important that all piping be lined up and not forced into place. It is recommended that you begin piping at the pump. If the lines are ended at the pump, particularly if the last piece is cut a little too short or long, the pump will be forced to meet the pipe and strain or distortion will result.

2E2 Piping Support

Never allow the pump to support piping. Other means such as pipe hangers and pipe supports should be used to carry piping to avoid misalignment and distortion. Consideration should be given to thermally induced expansion and contraction, particularly in long runs of straight pipe.

2E3 Piping Size

In general, outlet and especially inlet pipe sizes should be equal to or larger than those of the pump.

2F Typical Installation (Refer to Figure 2-5)

Figure 2-5 shows a typical pump installation, note the use of pipe hangers and support and the position of piping, valves, and components.

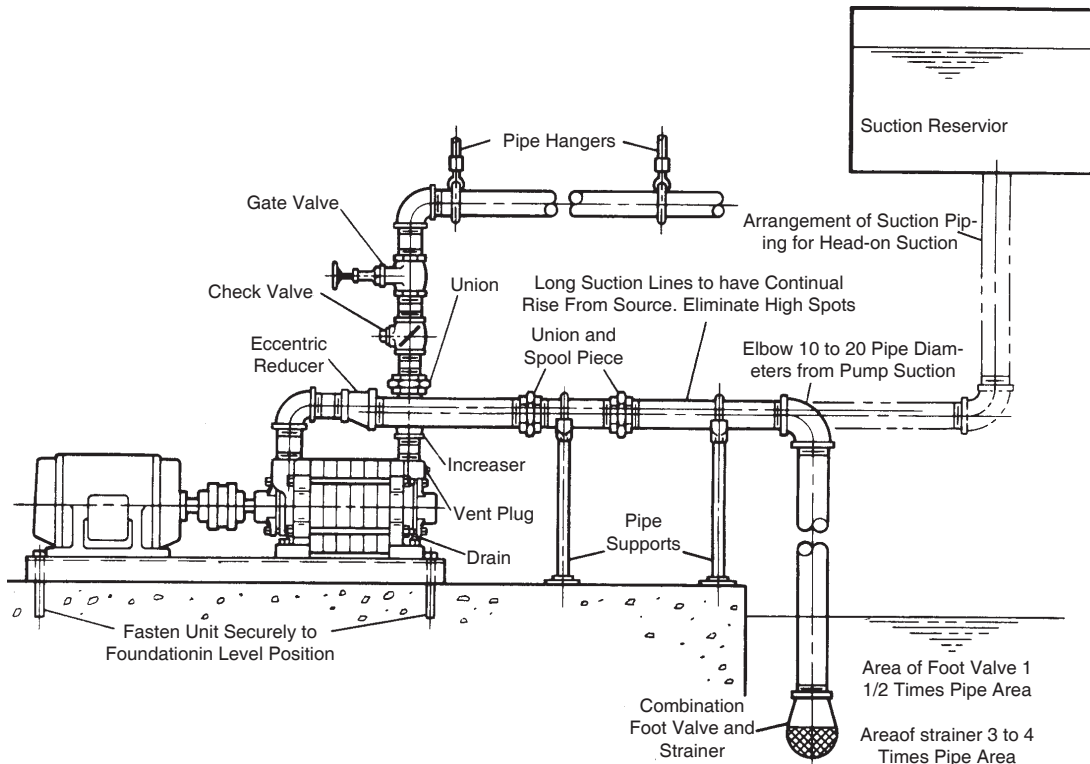

Figure 2-5

240 • 280 SERIES

3. Operation

FLEXIBLE COUPLED PUMPS

- A. Rotation
- B. Foreign Material
- C. Electrical
- D. Adjustments
- E. Cooling Water
- F. Priming
- G. Starting
- H. Stopping

3A Rotation

The standard direction of rotation for the pump is right-handed, or clockwise when looking at the motor end of the pump. A rotation arrow, refer to Figure 3-1, is located on the pump to indicate the correct direction of rotation.

Operating the pump in reverse will cause substantial performance variations and can damage the pump.

Always confirm correct motor rotation prior to connection of the coupling. If this is not possible, perform a final rotation check as follows:

1. Jog the motor briefly.
2. Observe rotation as the unit comes to a stop.
3. Rotation should be in the direction of the arrow.

If the motor operates in the wrong direction:

1. Interchange any two leads on a three-phase motor.
2. On a single-phase motor, change the leads as indicated on

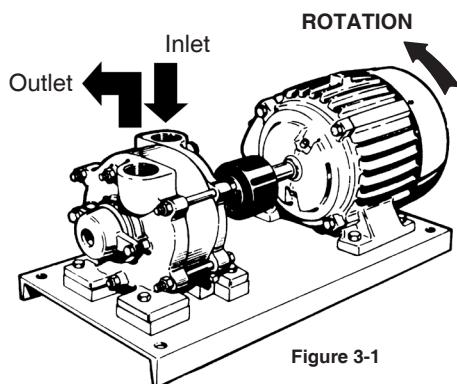

Figure 3-1

the connection box cover. Some single-phase motors may not be reversible.

3B Foreign Material

All regenerative turbine pumps have close running clearances in order to maintain efficiency. Take extra precautions to insure that no foreign material larger than 25 microns or .001 inches is allowed to pass through the pump. Even particles of this size can damage the pump if allowed to circulate continuously. Regenerative turbine pumps are not designed for slurries.

Large particles, weld spatter, and other material found in new piping systems will bend the impeller vanes and can sometimes lock up the pump. If a new pump does not operate properly, the first thing to check for is damage from foreign material.

3C Electrical

It is important to be aware of and follow the appropriate local and national electrical codes. Do not make wiring alterations that can affect motor rotation without reconfirming correct rotation.

3D Adjustments

No adjustments are necessary or advisable on new pumps. In view of the close fits however, it is not uncommon for regenerative turbine pumps to be difficult or impossible to turn over by hand by the time they have been shipped, mounted and allowed to dry out inside. In these cases, it may be necessary to fill the pump with fluid and loosen the thru-bolts exactly one turn. (loosen guide rods also on the pumps that have them - see appropriate assembly drawings). DO NOT LOOSEN BEARING ARMS - they are difficult to adjust except as part of the assembly or reassembly process. With the thru-bolts loose, light tapping with a soft mallet on the exposed end of the pump shaft along with torque applied to the coupling should have the desired effect. If possible, spin the pump (or operate

with minimal discharge pressure) while the thru-bolts are retightened exactly one turn. This will allow residue to be flushed from close fitting ring and impeller surfaces. With the large close fitting surface area inside regenerative turbine pumps, it takes only microscopic residue to produce substantial resistance to rotation. Once loosened however, this material is quickly dispersed. Impellers quickly find their hydraulic center. Normal operation may be expected.

3E Cooling Water

When the pump is used to transfer hot fluids, consideration should be given to cooling the seals and/or selecting materials that will give satisfactory seal life. The actual temperature at the seal faces, the most critical area, will always exceed the surrounding fluid temperature.

3F Priming

Pumps should not be operated unless they are completely filled with liquid. Damage to parts of the pump that depend on liquid for their lubrication can occur. Impellers can seize quickly when a pump is run dry. Without lubrication, seal faces can be damaged from heat buildup.

3G Starting

Before starting a pump for the first time, be sure that all the preceding operations have been carried out. Proper rotation, priming, and a free turning pump are most important.

1. Start the pump with the minimum possible line restriction.
2. Open discharge valves before pressing the starter.
3. Start the pump and let the system clear of air.
4. Listen for foreign material being carried through the pump.
5. Slowly close necessary valves or otherwise place the pump into service.

6. Listen for indications of undue load or other sounds indicating problems.
7. Use a clip-on ammeter to check for a steady load after approximately fifteen minutes of operation.

3H Stopping

It is best to stop the pump with the least discharge head possible both for minimizing strain on components, and to be in low power mode in anticipation of restarting.

240 • 280 SERIES

4. Service

PUMP ENDS

- A. Preliminary
- B. Tools and equipment
- C. Disassembly
- D. Inspection of components
- E. Reassembly
- F. Testing and final adjustments

4A PRELIMINARY

Before pump service begins, note the details of the system prior to removal of the pump. This is sometimes helpful in determining the cause of failure when pump life has been less than expected.

Disconnect inlet and outlet piping. Disconnect and separate coupling halves. Remove any dowel pins from the pump feet. Remove pump mounting bolts. Lift the pump carefully from baseplate. The feet are easily broken if the pump is dropped. A hoist or other mechanical lifting aid may be necessary on larger models.

4B TOOLS AND EQUIPMENT

1. Soft mallet
2. Two jaw gear puller
3. Snap ring pliers
4. Two large screwdrivers
5. Wood blocks as shown
6. Side cutters
7. Penetrating oil
8. 5/16" drive pin punch
9. Set of metal numbering stamps
10. 10 or 12 inch crescent wrench
11. 9/16" box end wrench or socket
12. 9/16" open end wrench

4C DISASSEMBLY

1. Starting at the discharge end of the pump, remove the four nuts (#20) and four thru bolts (#19).
2. Remove the two nuts (#20) that hold the outboard bearing arm (#3) in position.

3. The bearing arm (#3) may now be removed. A gear puller may be necessary. (refer to figure 4-1) The outboard ball bearing (#24) should now be removed. A gear puller will have to be used for this operation. If the bearing can be removed too easily, a worn bearing surface may be indicated. Replace the shaft and bearing as necessary before reassembly.

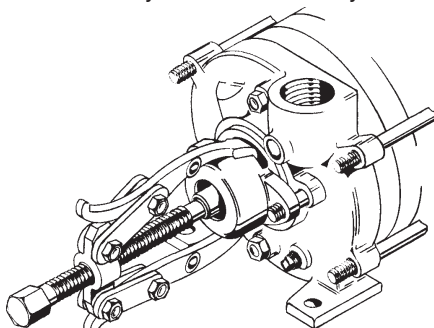

Figure 4-1

4. Slide the flinger (#21) off the shaft.

5. Carefully loosen the two remaining nuts (#20). Relieve the tension evenly by turning each nut a little at a time. This will prevent the guide rods from becoming distorted.

6. Using a soft mallet, loosen the outboard cover (#1) by tapping lightly around the outside edge. Slip the cover off the guide rods (#18) being careful not to bend them.

7. The seal cup (#2) may be removed by tapping it towards the inside of the cover (#1). Using a wooden block or dowel for this operation, rather than something metal, will prevent damage to the seal cup or seal seat (#12.5).

8. If the seal seat (#12.5) must be reused, use a wooden dowel sized to fit through the hole in the seal cup to tap it out. (refer to figure 4-2) Ceramic seal seats are particularly

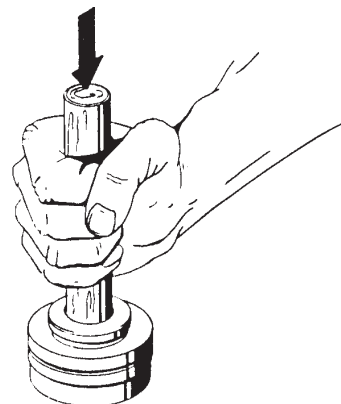

Figure 4-2

easy to damage. Normally, always replace the seats when servicing the pump.

9. Slide the outboard seal rotating element (#12 or #13) from the shaft. If the rotating element cannot be removed easily, it may be necessary to apply penetrating oil or some other lubricant compatible with the seal material. If any doubt exists as to what type of elastomer is used in a particular seal element, check the purchase records. Reuse of seals is not recommended, regardless of its apparent condition, and replacement during reassembly is usually a wise choice. One & two stage pumps use a 7/8 inch type 21 Crane or equivalent seal while three & four stage pumps utilize a 1 inch type 21B Crane or equivalent seal on the high pressure end only.

10. Remove the two "O" rings (#8) from the guide rods (#18).

11. If a complete disassembly is to be performed, all the channel rings (#9 & #10) should be suitably marked at this time so that the original orientation and position can be retained during reassembly. Note or mark these rings such that the top to bottom relationship as well as the order is maintained. Number stamps

are preferable to less permanent markings which tend to be lost during cleaning.

12. Gently tapping the rings around the outside edges with a soft mallet will loosen them. Separate the first channel ring (#9) and slide it off the guide rods exercising care to prevent damage. Should prying be necessary, it should be done evenly and with great care.
13. On three & four stage pumps, the drive collar (#14) must be removed before further disassembly can continue. A small screwdriver or pocket knife can be useful for this task. Damage to the ring groove should be avoided.
14. Slide the impeller (#11) off the shaft. Penetrating oil should be used if resistance occurs. Prying impellers off the shaft almost always ruins the impeller.
15. Remove the next channel ring (#10) using the same care as with the first.
16. Remove the key (#23) from the shaft. Diagonal side cutters or end nippers are helpful for this job.
17. For disassembly of single stage pumps (241 models) proceed to step #20. For all other models (242, 243, & 244) proceed to next step.
18. Slide off the next channel ring (#9). Along with the ring will come an interstage bushing (#16). Note the direction the bushing is facing so that the same surfaces will be in contact after reassembly.
19. Remove the remaining channel rings, impellers and interstage bushings. Stacking the parts as they are removed will help in maintaining the proper orientation and in keeping the impellers with the same pair of channel rings. On badly corroded pumps it may be easier to drive the guide rods (#18) back through each ring rather than sliding the ring the entire length of the rods. If this is to be done, care should be taken not to "mushroom" the rod ends by tapping with too much force. A soft face hammer and/or brass rod

is recommended. Penetrating oil helps greatly.

20. Turn the pump around and remove the two nuts (#20) holding the bearing arm (#3) in place.
21. Removing the bearing arm will require the use of a gear puller since the bearing (#24) is held in the bearing arm by means of a snap ring (#4). Removal of the bearing arm will bring the bearing along with it.
22. Slide the rubber flinger (#21) off the shaft.
23. The remaining internal parts; the shaft (#17), diffuser (#91N), centrifugal impeller (#11N), and the seal rotating assembly (#12) will slide easily out of the cover (#1).
24. The diffuser (#91N) will separate easily from the impeller (#11N).
25. The shaft extension end seal element (#12) can be removed in the same manner as was the outboard rotating element.
26. Remove the drive collar (#14) from inside the eye of the centrifugal impeller (#11N). Tapping lightly on the shaft should separate the two. Remove the remaining key (#23) and drive collar.
27. To complete the disassembly, remove the two "O" rings (#8) and two guide rods (#18).
28. Press out the shaft extension end stationary seat (#12.5) using the same procedure as on the outboard seat.
29. The remaining seal cup (#2) can be removed from the cover by driving it outward from the inside.

4D INSPECTION OF COMPONENTS

Thoroughly clean all parts. All components should be examined for wear and corrosion. Replace parts that show visible wear. If the pump was no longer producing sufficient pressure or capacity, it is a safe assumption that clearances

between rings and impeller exceed an acceptable amount. At least the impellers should be replaced in this case. If the total side running clearance for an impeller exceeds .007", it is unlikely that pump performance will reach that of a new pump except at lower discharge pressures.

"O" rings and other elastomeric components should be replaced if they have been deformed or cut.

If seal components must be reused, carefully inspect for microscopic cracks and nicks. Scratches that might be ignored elsewhere can produce leakage if they are on seal carbons and seat wearing surfaces. Cleanliness is imperative when working with mechanical seals. Almost unnoticeable particles between seal faces can be, and often are, the cause of early seal failures.

Check to be certain that a press fit still exists between the shaft and the bearings. New bearings, or at least cleaned and regreased bearings, are recommended.

All impellers and interstage bushings are designed to float, therefore they should move easily on the shaft. No more than .010" diametral clearance should exist between the shaft and the inside of an interstage bushing. More than this can produce hydraulic unbalance that can quickly wear out the impellers. As long as impellers can be moved on the shaft by hand, they are loose enough. If they can be rocked or wobbled, they are definitely too loose and must be replaced.

Check the shaft for galling, pitting, and corrosion. If there are worn areas between stages of multistage pumps, the shaft should be replaced. Pitting or corrosion in the area where the seal comes in contact is also cause for shaft replacement. This will cause leakage under the seal. Surface corrosion must be removed so that seals can slide freely during assembly. The shaft diameter should be no smaller than .002 inch below the nominal fractional seal sizes. Remove any nicks or burrs which may have occurred during disassembly. Reclean parts as necessary.

4E REASSEMBLY

1. Begin reassembly with the inlet cover (#1). Thread two nuts (#20) onto the shorter threaded end of the two guide rods (#18), and slide them through the two holes at six and twelve o'clock. Push them in until the underside of the nuts contacts the cover.
2. Slide two "O" rings (#8) over the extended ends of the guide rods until they touch the cover.
3. Assemble the centrifugal impeller (#11IN) and shaft (#17) by sliding the impeller into position with its inlet opening facing the coupling end of the shaft.(refer to figure 4-3) Place one key (#23) into position before centering the impeller between between the two snap ring grooves located nearest the coupling end. Place a drive collar (#14) into each of these snap ring grooves.

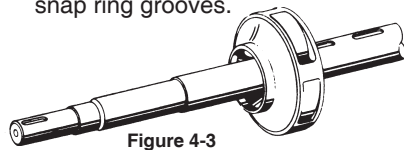

Figure 4-3

4. Insert the shaft/impeller assembly into the diffuser (#9IN). When correctly oriented, the impeller outlet openings will line up with the diffuser openings and the impeller hub will fit into the bore of the diffuser.(refer to figure 4-4)

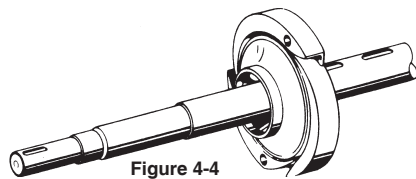

Figure 4-4

5. Now slide this entire assembly of shaft, impeller, and diffuser onto the guide rods (#18) and into the cover (#1IN).(refer to figure 4-5) The diffuser should fit flush. The original diffuser vane orientation is preferred, but either guide rod hole may be up. The chamfer around these holes are for two "O" rings (#8).

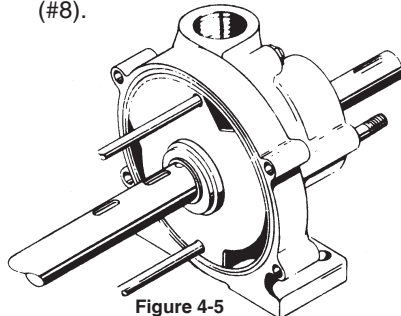

Figure 4-5

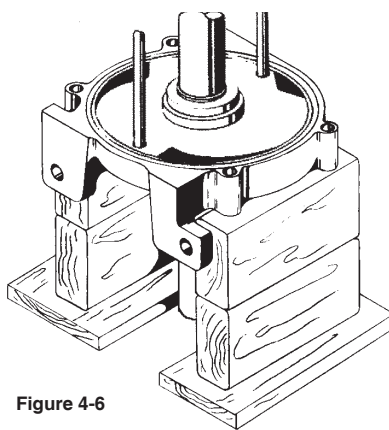

Figure 4-6

6. For the remaining operations, it is recommended that the assembly be placed on blocks in a vertical position with the coupling end of the shaft facing downward.(refer to figure 4-6)

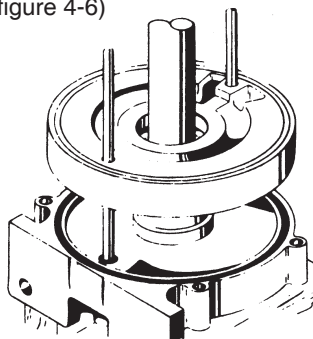

Figure 4-7

7. Place an "O" ring (#7) into the groove in the face of the cover (#1). Slide a left hand channel ring (#10) onto the guide rods with the water channel facing up.(refer to figure 4-7) With the pump feet in the "six o'clock" position, the large inlet opening should be at "eleven o'clock".
8. Put another "O" ring (#7) and a key (#23) into place.
9. Slide an impeller (#11) onto the shaft (#17) and over the key (#23) nearest the drive end.(refer to figure 4-8) Place the impeller-shaft assembly into the ring, with

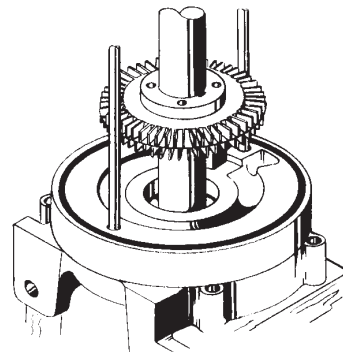

Figure 4-8

the shaft extension down. If the blocking is the correct height, the shaft end should contact the bench at the same time the impeller covers the key.

10. Slide a right hand channel ring (#9) onto the guide rods with the water channel facing downward, toward the impeller.(refer to figure 4-9) The small outlet opening should be in the "one o'clock" position. This completes one stage; a stage consisting of one left hand channel ring (#10), a right hand channel ring (#9), and an impeller (#11) between them.

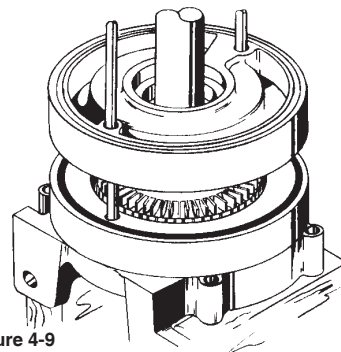

Figure 4-9

11. Single stage pumps (141 model) should proceed to step #17. Pumps with more than one stage (models 142, 143, or 144) proceed to next step.
12. Slide an interstage bushing onto the shaft. The smooth wearing face should be installed against the ring (#9).(refer to figure 4-10)
13. Place another "O" ring (#7) into position.

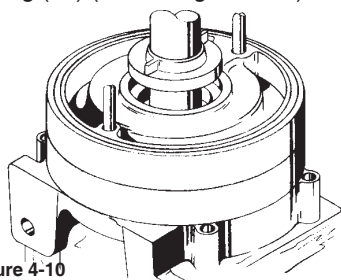

Figure 4-10

14. Slide another left hand channel ring (#10) into place with the water channel facing up.(refer to figure 4-11) This time, however, place the large inlet opening in the "five o'clock" position. By locating successive stages 180 degrees from the last, hydraulic loads are radially balanced.

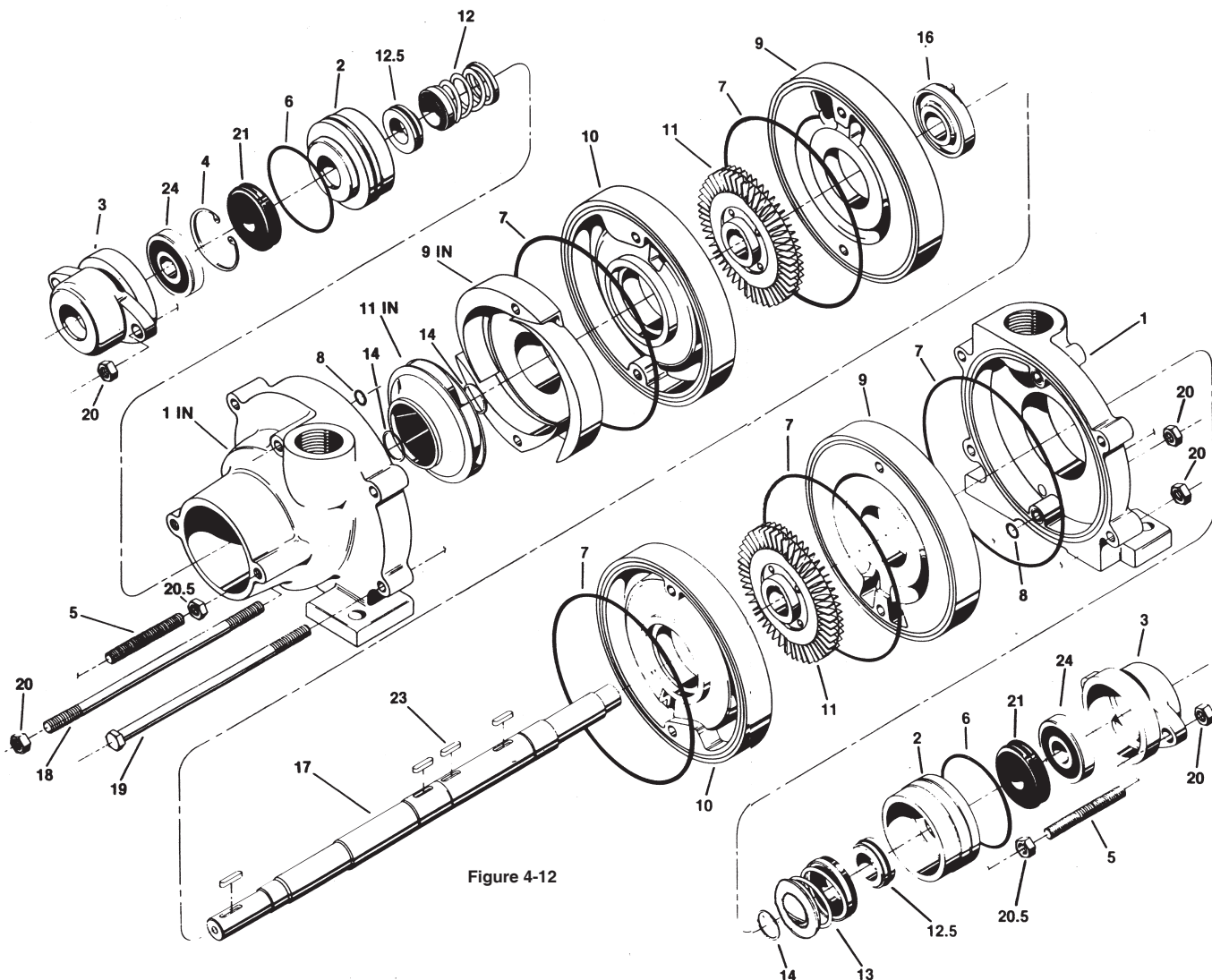

Figure 4-12

Part No.	Name	Description	Part No.	Name	Description
1	Cover	Discharge	12	Seal Rotating Element	Unbalanced (inlet end- all pumps) (outlet end- 241 & 242 series)
1 IN	Cover	Inlet	12.5	Seal Stationary Seat	Both Seals
2	Seal Cup		13	Seal Rotating Element	Balanced (outlet end- 243 & 244 series)
3	Bearing Arm		14	Drive Collar	Spirolox
4	Snap Ring	Bearing Retaining (inlet end only)	16	Interstage Bushing	(242, 243, 244 series)
5	Stud	Bearing Arm	17	Shaft	
6	"O" Ring	Medium- Seal Cup	18	Guide Rod	
7	"O" Ring	Large- Casing	19	Thru Bolt	Casing
8	"O" Ring	Small- Guide Rod	20	Nut	Casing and Bearing Arm
9	Channel Ring	Right- 140R (outer end ring)	20.5	Jam Nut	Bearing Arm
9 IN	Diffuser	Inducer	21	Flinger	
10	Channel Ring	Left- 140L (inlet end ring)	22	Drain Plug	
11	Impeller	Turbine	23	Key	Impeller and shaft
11 IN	Impeller	Centrifugal	24	Ball Bearing	Sealed

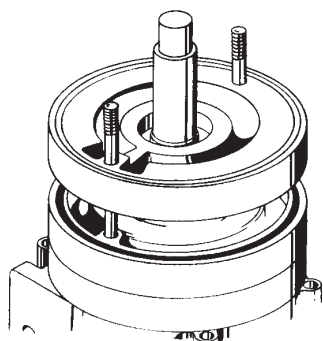

Figure 4-11

15. Add another Key (#23) and an impeller (#11).

16. Put another "O" ring (#7) into place.

17. To complete the second stage assembly, install a right hand channel ring (#9) facing downward toward the impeller.(refer to figure 4-13) The small discharge opening should be in the "seven o'clock" position.

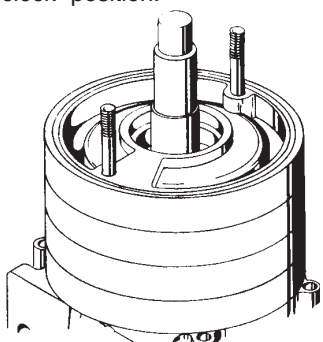

Figure 4-13

18. Continue installing stages depending on how many stages are in the pump. Don't forget the interstage bushings and the "O" rings (#7). Remember also to stagger the ring sets to balance radial loads. The odd numbered stages should have openings at the top of the pump as described for the first stage installation. Even numbered stages should have their openings downward as indicated for the second stage.

19. After the last impeller has been installed in three or four stage pumps, a drive collar (#14) must be installed to locate the seal rotating element. If the groove is hidden, tap the shaft gently from the coupling end until it just becomes visible.

20. Add the last "O" ring (#7) and two "O" rings (#8) onto the guide rods (#18).

21. Slide the cover (#1) over the exposed guide rods bringing it up against the last channel ring. Check to make sure the feet on both covers are in the "six o'clock" position.

22. Install two nuts (#20) onto the guide rods and tighten enough to hold the entire assembly in place. Do not try to tighten them to their final position.(refer to figure 4-14)

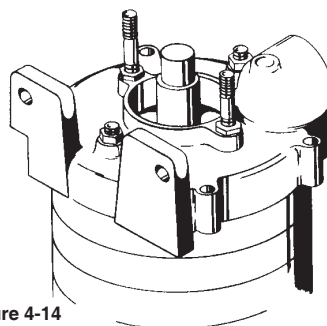

Figure 4-14

23. Carefully press seal seats (#12.5) into both seal cups (#2).(refer to figure 4-15) A clean soft material should be used between the seal face and pressing tools. The smoothest side of the seat should face up. Caution: Dirt and scratches can quickly ruin seals. Place an "O" ring (#6) into the groove around each seal cup.

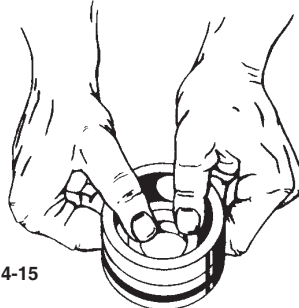

Figure 4-15

24. When installing seats and rotating elements, a thin film of compatible lubricant may be applied to seal surfaces. This will help seals to become mated when they first come in contact. Glycerine, ethylene glycol, and mineral oil are sometimes selected for use on standard seals which use EPR elastomer. Do not use a petroleum based lubricant in standard seals.

25. The seal rotating element can now be installed.(refer to figure 4-16) One and two stage pumps position both seals (#12) by a shoulder on the shaft. Three and

four stage pumps locate the rear seal (#13) by means of a drive collar (#14). The seal rotating element, when lubricated, must be allowed to move freely on the shaft. This will enable the seal to seek a hydraulic balance upon operation.

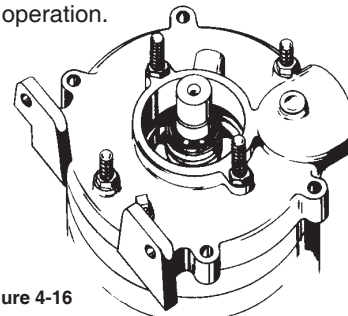

Figure 4-16

26. Install the seal cup with the face of the seal towards the rotating element. A short length of pipe will help to tap the cup down until it contacts the ring.(refer to figure 4-17)

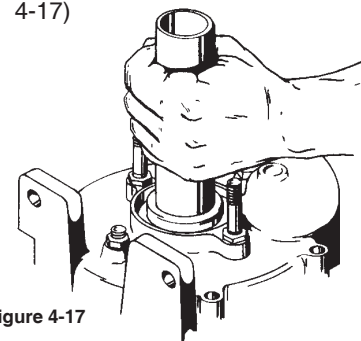

Figure 4-17

27. Press a flinger (#21) onto the shaft until it is against the seal cup.

28. Solidly supporting the bottom end of the shaft, drive or press a ball bearing (#24) onto the shaft until it rests firmly against the shoulder on the shaft.(refer to figure 4-18) A sleeve properly sized to contact only the inner bearing race will be helpful for this operation.

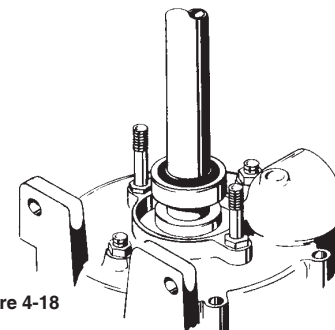

Figure 4-18

29. Tap a bearing arm (#3) over the bearing and retain with two nuts (#20). They should be finger tight only.

30. Remove the pump from the support blocks and place it on its feet.
31. Insert the four thru bolts (#19) and install nuts (#20). Tighten all six nuts evenly until about one full turn before being fully torqued. Return the assembly to the wood blocking with its shaft extension up. Install the seal rotating element (#12), seal cup assembly (#2), and flinger (#21) with the same procedure as on the other end.
32. Drive a ball bearing (#24) into a bearing arm (#3), applying force to the bearing's outer race only. Insert a snap ring (#4) into the groove provided in the bearing arm. The beveled side of the snap ring faces away from the bearing.
33. Place a metal support under the shaft opposite the extension. A 3/8" or 1/2" nut works well. The pump will be unstable in this position. It is well to have necessary tools at an easy reach. Drive the bearing arm assembly onto the shaft until the bearing rests against the shoulder provided. Driving should be done with a sleeve contacting the inner race only. (refer to figure 4-19) Secure with two nuts (#20), finger tight.

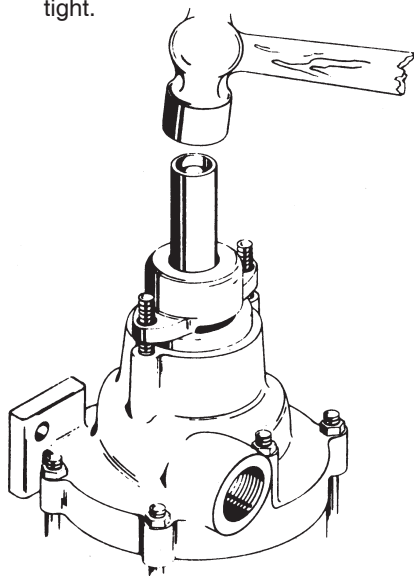

Figure 4-19

5F TESTING AND FINAL ADJUSTMENTS

1. Check to be sure the pump rotates freely. If not, Determine why and resolve any problems before proceeding. Incorrect assembly or the presence of foreign material has probably occurred.
2. For optimum final adjustment, remount the pump, make coupling and piping connections. Check for correct rotation.
3. Open inlet and outlet valves and start the pump when fluid has displaced air from it. The pump may leak at this time, but a fully open discharge should prevent substantial fluid losses.
4. Evenly tighten all six nuts (#20). A noticeable change in RPM is an indication that the nuts are not being tightened evenly. Torque to 20 foot pounds.
5. Evenly tighten the two nuts (#20) on the driver end bearing arm. Torque no higher than 5 foot pounds. If signs of distress are evident, back off evenly until the pump runs smoothly again. Lock the bearing arm in place by turning the two jam nuts (#20.5) in a counterclockwise direction. The bearing arm is now correctly positioned and should remain so until service is again required.
6. Evenly tighten the two nuts (#20) on the discharge end of the bearing arm. With a new pump or one with new rings and impellers, these nuts cannot be tightened very much before distress becomes noticeable. Back off slightly until the pump runs smoothly. Use the two jam nuts (#20.5) to lock this bearing arm in position as was done in step #5. (On an older pump, the nuts (#20) on both ends may be tightened up to 20 foot pounds. Depending on the condition of the pump, tightening these nuts can improve and sometimes restore performance. Jam nuts (#20.5) should always be loose enough to allow sensitive adjustment of bearing arms when performing these operations. Turn them counterclockwise until they contact bearing arms when adjustments are complete.
7. This completes the necessary adjustments. The pump is now ready for service.
8. If an Amprobe or other current measuring device is used as the system is returned to normal operation, a variation or wavering will be noticed as the pump impellers seek their hydraulic balance. It sometimes requires a few hours or even days to complete this positioning.

5. Troubleshooting

FLEXIBLE COUPLED PUMPS

- A. Failure to Pump
- B. Reduced Capacity
- C. Reduced Pressure
- D. Pump Loses Prime After Starting
- E. Excessive Power Consumption
- F. Pump Vibrates or is Noisy
- G. Mechanical Problems
- H. Seal Leakage

5A Failure to Pump

1. Pump not up to speed — Use Tachometer to determine actual RPM. Check voltage and wiring connections.
2. Pump not primed — Confirm that pump and all inlet piping are filled with fluid.
3. Discharge head too high — Install a pressure gauge at the pump discharge to determine the actual operating pressure. Compare readings with pump performance curve. A larger pump may be necessary.
4. Excessive suction lift — Relocate pump, supply tank, or both to minimize suction lift.
5. Wrong direction of rotation — Compare pump rotation with arrow on pump. Standard pumps rotate in a clockwise direction when looking at the shaft extension end or from the motor end on close-coupled pumps. Reverse two leads on a three-phase motor to change rotation. Check motor nameplate for single-phase operation.
6. Clogged suction line, strainer, or foot valve — Inspect and clean out if necessary.
7. Air pocket in suction line — Look for high spots in inlet piping system. Evacuate the system with a vacuum pump if necessary.

5B Reduced Capacity

1. Pump not up to speed — Use a tachometer to determine actual

RPM. Check voltage and wiring connections.

2. Excessive suction lift — Relocate pump, supply tank, or both to minimize suction lift.
3. Insufficient NPSH — Relocate pump, supply tank, or both to improve NPSH available if possible. Increase suction pressure. Reduce fluid temperature. Select a pump with lower NPSH requirements.
4. Mechanical damage — Rotate the pump by hand to determine if there are tight spots. Broken or bent impeller vanes can sometimes be detected in this manner. If there is a suspicion of damage, remove the pump from service and disassemble for inspection.
5. Air leak in the suction line — Fill the system with fluid and hydrostatically test. Tighten connections or replace leaky components.
6. Air pockets in the suction piping — Operating the system at maximum flow conditions will usually clear the lines. Evacuate the system with a vacuum pump if necessary.
7. Suction lines, strainer, or foot valve too small or clogged — Inspect and clean out as necessary. Fittings and lines should be at least equal to the pump suction size.
8. Discharge head too high — Install a pressure gauge at the pump discharge to determine the actual operating pressure. Compare readings with pump performance curve. A larger pump may be necessary.
9. Excessive wear — If a pump had previously performed satisfactorily and now gives evidence of reduced performance, it should be disassembled and examined for wear after the simpler

possible problems have been investigated.

5C Reduced Pressure

1. Pump not up to speed — Use a tachometer to determine actual RPM. Check voltage and wiring connections.
2. Air or vapor in liquid — Install a separator in the suction line. Check the seal on the inlet end of the pump to determine if air is being drawn in. Hydrostatically test the system to insure that there are no leaks.
3. Mechanical wear or damage — Rotate the pump by hand to determine if there are tight spots. Broken or bent impeller vanes can sometimes be detected in this manner. If there is a suspicion of damage or wear, remove the pump from service and disassemble for inspection. Look for wear on the impeller and channel rings.
4. System head less than expected — Replace pump with higher capacity unit or add a valve or orifice to increase line resistance.

5D Pump Loses Prime After Starting

1. Leak in suction line — Fill the system with fluid and hydrostatically test. Tighten connections or replace leaky components.
2. Air entering pump through inlet seal or “O” rings — Hydrostatically test the pump and look for leaks. Replace faulty seals or “O” rings.
3. Insufficient NPSH or too much suction lift — Relocate pump, supply tank, or both to improve inlet conditions. Increase suction pressure. Reduce fluid temperature. Select a pump with lower NPSH requirements.

5E Excessive Power Consumption

1. Speed too high — Check RPM with tachometer.
2. Discharge head too high — Install a pressure gauge at the discharge to determine the actual operating pressure. Compare readings with pump performance curve. A different pump, motor, or both may be necessary.
3. Specific gravity or viscosity too high — Check fluid involved. A different motor may be necessary.
4. Mechanical damage — Turn pump over by hand. After a few days run-in period, all models should turn over by hand with no tight spots. An exception to this is when the pump has been idle for some time. In this case, run the pump for a few hours before checking for tight spots. If there is a suspicion of damage, remove the pump from service and disassemble for inspection.
5. Pump not fully “broken in” — It is normal for new pumps to consume higher than normal current during the break-in period. If high power consumption persists beyond a few weeks, it is unlikely that further operation will reduce consumption.
6. Pump not properly adjusted — Loosen all nuts on pump exactly one turn. Follow the instructions in Section 4F Testing and Final Adjustments, for repositioning fasteners.

5F Pump Vibrates Or Is Noisy

1. Pump and motor are misaligned — Follow the instructions in Section 2D Alignment, for proper alignment.
2. Insecure mounting — Follow instructions in Section 2, 2B Foundation.

3. Piping load on pump — Install piping supports and check to see that there is no strain on the pump.
4. Mechanical damage — If mechanical damage is suspected, check first to determine if the pump turns freely. Disassemble for inspection if tight spots are found.
5. Pump has a high pitched whine — This is typical of a regenerative turbine pump. The intensity should increase as pressure increases. Over a period of a few weeks the noise level will diminish and will be noticeably quieter as it approaches a “run-in” condition.

5G Mechanical Problems

1. Short bearing life — Bearings damaged due to leaky seals. Coupling misalignment. Piping load on pump. RPM or pump pressure too high.
2. Pump locked up — Pump dried out and close clearance areas rusted. Follow installation instructions for loosening the pump. Foreign material in pump. Flush out. Disassemble if flushing is not successful.
3. Pump leaks — Seal or “O” rings are usually the problem. Disassembly and replacement is the solution if tightening the thru bolts has no effect.

5H Seal Leakage

1. Worn seat or rotating element — Seals will last many years operating on cold clear water or other fluids with reasonable lubricity. Particles, even microscopic, increase normal wear rates. Temperatures near the fluid’s boiling point can reduce lubricity, which in turn increases wear. Some chemicals will erode the seal faces or plate out on the faces producing an abrasive effect.

Immediate seal replacement is recommended when leaks become evident, since bearings are quickly ruined when exposed to moisture. Severe mechanical damage results when the bearings fail.

2. Improperly installed seat or rotating element — If a seal has recently been replaced, look for a missing “O” ring/cup around the seat, or a seat that was installed cocked or backwards. The smooth surface should face the rotating element. The rotating element may be in backward or improperly positioned. Refer to the appropriate seal diagrams and instructions to confirm the correct seal orientation. Rotating elements sometimes stick in the wrong position if left partially assembled for some time. Make sure a rotating element can be moved axially on the shaft before closing up the pump, and then make the final adjustments as soon as possible.
3. Seat broken during assembly — Ceramic seats are particularly vulnerable to damage. Carefully follow reassembly instructions for seals. Seals on flex-coupled units can be damaged by excessive hammering when installing the coupling onto the shaft extension.
4. Pitted shaft under the seal — Reusing a shaft or sleeve when repairing a pump is the probable cause of this problem. The seal rotating element can produce a pitted surface underneath its elastomer portion during normal use. This is normally not a problem for the first seal assembly since the elastomer is conforming as this action occurs. A new seal can leak before it conforms if the pits are large enough. If any pits are visible to the unaided eye, shaft or sleeve replacement is advised.

6. Parts and Repair Services

- A. Parts
- B. Repair Service
- C. Warranty Service
- D. Motors, Mechanical Seals, and Accessories

6A Parts

Repair parts may be obtained through your local Authorized MTH Pumps Representative or Distributor who can be found in the yellow pages or by contacting MTH Pumps at:
401 W. Main St. • Plano, IL 60545
Phone: 630-552-4115
Fax: 630-552-3688.

6B Repair Services

Repair service for an MTH pump should be obtained from the company through which it was purchased.

In the event this is not possible, the name and phone number of a nearby MTH representative or distributor may be obtained by contacting MTH Pumps. In the event that it is necessary to return the pump to the factory for repairs, remove all accessories attached to the pump. We cannot accept responsibility for their safe removal, storage, and return.

6C Warranty Service

All requests for warranty claims should be made through the company from which the pump was purchased or supplied. Complete details on what is wrong with the pump must be provided along with information on the system in which it is installed. Refer to the MTH Pumps

Limited Warranty statement. Return authorization must be obtained prior to returning any equipment.

6D Motors, Mechanical Seals, and Accessories

Repair or replacement service on motors, mechanical seals, relief valves, or other accessories should be obtained from the manufacturer of these components. MTH does not carry replacement parts and is not authorized to render repair service on these components. Replacement mechanical seals are stocked at MTH and are always available insofar as possible for immediate shipment. Warranty service, as well as expert application information can be obtained from your local seal manufacturer's sales office.

7. Limited Warranty

MTH makes good faith recommendations of Products, based on its experience and the application information provided by the Purchaser. However, the responsibility for testing and approving a Product to be used for a particular purpose lies with the Purchaser.

The obligations of MTH Tool Company, Inc. (hereinafter referred to as "MTH"), with respect to a "Product" (defined below) are limited as set forth herein.

ALL IMPLIED WARRANTIES, including the "implied warranty of merchantability" and the "implied warranty of fitness for a particular purpose" are HEREBY DISCLAIMED.

There are no warranties which extend beyond the description on the face hereof.

MTH warrants that, during the "Warranty Period" (defined below), the "Product" (defined below) will not fail to meet the "Operational Specifications" (defined below), within applicable industry tolerances established by the Hydraulic Institute, due to defects in its materials and workmanship. MTH does not warrant that any Product will meet the "Operational Specifications" in conditions other than the Standard Operating Conditions, unless agreed to by MTH in a signed writing.

For all purposes of this Limited Warranty:

- (a) The term "Warranty Period" shall mean the twelve (12) month period from the date of shipment from MTH to the Purchaser (the "Warranty Period").
- (b) The term "Product" shall mean: any item or assembly of items sold by MTH that are either manufactured or selected by MTH to meet the "Operational Specifications". The term "Product" does not include any item, assembly of items, or portion of such assembly that is selected or specified by any entity other than MTH, or that MTH has identified as ineligible for warranty coverage.
- (c) The term "Purchaser" shall mean the original person(s) or entity that issued the purchase order to MTH, for the Product.
- (d) The term "Operational Specifications" shall mean the specified dimensions, material composition, and performance parameters of a Product, as published by MTH, or as otherwise agreed in a signed writing between MTH and Purchaser. "Standard Operating Conditions", for pumps, shall mean: operating with clean water, at standard temperature and pressure. "Operational Specifications" shall not include visual appearance or any other parameters not expressly agreed to in writing.

If, within the Warranty Period, a Purchaser believes that a Product has failed to meet its Operational Specifications, the Purchaser must request a Return Goods Authorization ("RGA") in the manner specified at <http://www.mthpumps.com>, and supply any additional information MTH might reasonably request. If the Product was purchased through a distributor or any entity other than MTH, the RGA request must be made through that entity. Any Product returned without an RGA will be refused at the dock. Products authorized for return must be properly packaged to prevent further damage, clearly marked with the Return Goods Authorization "RGA" number provided by MTH, and shipped freight prepaid and allowed, F.O.B. the MTH factory at Plano, Illinois, USA.

MTH may, in its sole discretion, deny any warranty claim if shipping damage, any attempted disassembly, or any other action outside of MTH's control impairs MTH's determination of the existence of, or cause of a claimed failure.

Notwithstanding anything to the contrary in this Limited Warranty, MTH **shall have no obligation** to repair or replace any Product it determines to have any defects arising from or attributable to: (1) abrasion, corrosion, or erosion arising after shipment from MTH; (2) improper handling, packaging, installation, storage, or maintenance, after it is shipped by MTH; (3) repairs or alterations outside of MTH's factory, in any manner, without MTH's written authorization; (4) misuse, negligence, or accident after shipment from MTH; (5) use in a manner inconsistent with MTH's published instructions and Operational Specifications, or other written specifications agreed to by both Purchaser and MTH; or (6) incorrect power supply or power quality. MTH's determination with respect to the applicability of this Limited Warranty to any particular defect or Product shall be final and conclusive.

If, after examination by an authorized representative of MTH, MTH determines that the Product failed to meet the "Operational Specifications", within applicable industry tolerances established by the Hydraulic Institute, due to defects in its materials and workmanship, during the Warranty Period, then MTH will, at its option, ship a repaired or replaced Product to the Purchaser, F.O.B. MTH's factory in Plano, Illinois, U.S.A., freight prepaid and allowed. MTH will use a freight provider of its choosing, via a method no faster than that used for shipping the Product to MTH. MTH may, at its sole discretion, issue a credit memo to Purchaser for some or all Purchaser's shipping costs to return a defective Product to MTH.

MTH accepts no responsibility for costs associated with removal and reinstallation of Products.
Under no circumstances shall MTH be liable for incidental or consequential damages.

MTH neither assumes responsibility for, nor authorizes any person to assume for it, any other obligation in connection with the sale of any Product or any enlargement of this Limited Warranty.

Some States do not allow the exclusion or limitation of incidental or consequential damages. So, the above limitations or exclusions might not apply to you. This warranty gives you specific legal rights, and you might, also, have other rights, which vary from State to State.

By using this Product, you agree that this Limited Warranty is governed by the laws of the State of Illinois; that this Limited Warranty shall be interpreted and enforced only in accordance with the laws of the State of Illinois (excluding its conflicts of law provisions); and that you submit yourself to the jurisdiction of the 23rd Judicial Circuit, Kendall County, Illinois, which shall have exclusive jurisdiction over any controversy or dispute arising under or with regard to this Limited Warranty.



MTH PUMPS

401 West Main Street • Plano, IL 60545-1436
Phone: 630-552-4115 • Fax: 630-552-3688
Email: SALES@MTHPUMPS.COM
<http://WWW.MTHPUMPS.COM>